

WILLIAM DUBILIER
339 GARDEN ROAD
PALM BEACH, FLORIDA 33480

*The
Patents
older booklets
in "Catalogs"*



**CATALOGUE
AND
PRICE LIST**



**SEPTEMBER
1927**



DUBILIER

REGISTERED  TRADE MARK



CATALOGUE AND PRICE LIST

Sept. 1927

*The prices shown in this list cancel
all those previously issued and obtain
only in the United Kingdom of England,
Scotland, Wales and Northern Ireland.*

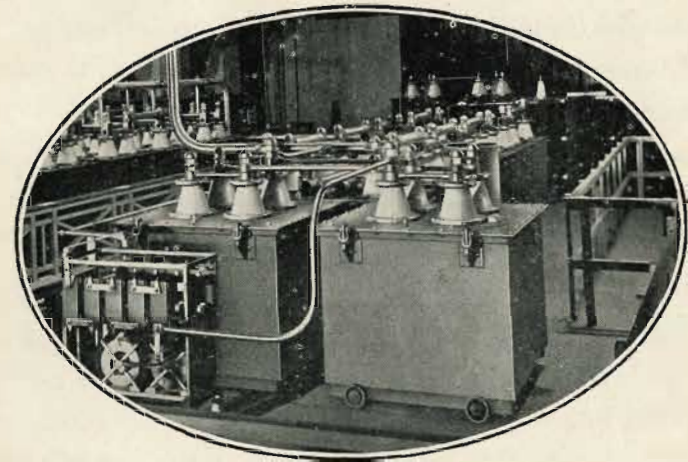

A BANK OF DUBILIER CONDENSERS AT THE
POST OFFICE RADIO TRANSMITTING
STATION AT RUGBY.

DUBILIER CONDENSER CO. (1925) LTD.
DUCON WORKS, VICTORIA ROAD
NORTH ACTON, LONDON, W.3

Telephone—Chiswick 2241-2-3

Telegrams—"Hivoltcon, Act, London"

Contents

	PAGE
Title	I
A Creed	3
Where Dubilier Products are made	4
Dubilier Mica Condensers, Type 577	6
Dubilier Mica Condensers, Type 610	6 & 7
Dubilier Mica Condensers, Type 620	7
Dubilier Mica Condensers, Type B775	8
The "Dubilicon"	8
Dubilier Mansbridge Condensers	9, 10, 11 & 12
The "Duwirohm" Resistance	14
The Non-Metallic Anode Resistance	14
The "Dumetohm" and Holder	15
Dubilier Filament Resistors	16
The "Duvarileak"	17
The "Duvolcon"	17
The Dubilier R.C. Coupling Unit	18
The Dubilier Toroids	20
The Dubilier "K.C." Condenser	21
The "Univane"	22
The Dubilier H.T. Supply Units	24 & 25
The "Dubrescon"	26
The "Ducon"	26
The "Minicap" Switch	27
The Dubilier Mansbridge Variometer	27
Dubilier Condensers for Special Purposes	28
Dubilier Agents	29
Price List	30 & 31

A Creed

A MISCELLANY of spare parts, cheap and cheerful, hooked together in a manner that defies every known law of Electrical Science—and giving first-class results.

You know this set ?

So do we.

All the same we design our components and we re-design them ; we make them up and then we scrap them and start all over again ; we worry over them and make an improvement here and another improvement there. We know all this means an increased cost, and sometimes it means that competing articles appear on the market while we are still trying to improve ours before we offer them to you.

Why do we do it ?

Well, we have been making Radio Components, particularly Condensers, for 16 years, perhaps a bit longer than most.

We know that, where Radio Sets are concerned, reliability and consistency of performance are more to be desired than great riches. So we try, we have always tried, to design and make Dubilier Products in such a manner that you can have confidence in them.

If this creed has earned for us a reputation for turning out reliable work, we are content.

Where Dubilier Products Are Made

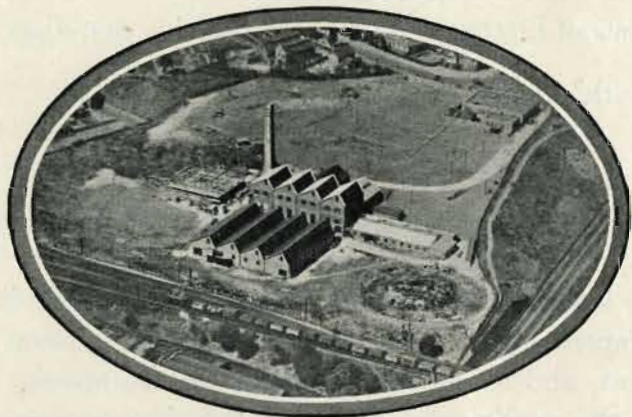

Dubilier Products are made at our Works, VICTORIA ROAD, NORTH ACTON, LONDON.

They are designed by eminent authorities whose names are widely known throughout the electrical world. These gentlemen have under them a staff of highly qualified scientists with our extensive Research Laboratories at their disposal.

The Operatives, of whom there are several hundreds, under their Foremen and Works Manager perform their skilled duties with the precision and understanding born of long experience, careful training and a genuine interest in the work.

The apparatus listed in this Catalogue is, for the most part, applicable to Broadcast Receivers.

The activities of Dubilier, however, extend in many other directions connected with Radio and Electrical Engineering. Transmitting condensers for almost every civilised Government have at one time or another left our works, and these range from small condensers for portable sets to complete condenser plant for such stations as that at Rugby (see page 28).

Dubilier Products have always been designed and manufactured in accordance with the highest engineering standards, and it is interesting to note that certain features of Dubilier Condensers exactly as supplied for use by the Public have been adopted as standards by the British Engineering Standards Association.

WILLIAM DUBILIER
339 GARDEN ROAD
PALM BEACH, FLORIDA 33480

SECTION ONE

Fixed Condensers

Dubilier Mica Condensers
Dubilier Mansbridge Condensers

Your Dealer stocks **DUBILIER** products—ask him

DUBILIER MICA CONDENSERS

The Dobilier Universal Condenser, Type 577

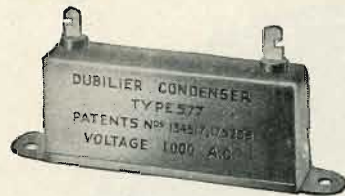

TYPE 577

THIS special Dubilier Universal Condenser is suitable not only for general use in all receiving circuits, but also for transmitting purposes—e.g. : D.C. transmitters and other valve transmitters up to 100 watts. The test voltage limits for the Type 577 are 2,000 volts D.C. or 1,000 volts A.C. (Low frequency). The larger capacities (above $0.0025\mu\text{F}$) of this type will carry

radio-frequency currents up to 1 amp. at the higher frequencies above 300 kilocycles.

The Dubilier Universal Condenser has a dielectric of the best Indian Ruby Mica, which is standard in all Dubilier Fixed Condensers, and the casing is finished in polished nickel. It can be supplied with tag terminals as shown, or with flexible wire connections, as required.

Standardised in capacities from $0.0001\mu\text{F}$ to $0.01\mu\text{F}$.

The accuracy of the rated capacity is guaranteed to within 10%.

For accuracy up to 5% the price will be 10% greater, and for accuracy up to 1% the price will be 15% greater than that shown for this condenser on page 30.

Dimensions :—Distance between fixing hole centres, $2\frac{1}{2}$ in.

PRICES—see page 30.

The Dubilier Mica Condenser, Type 610

THE Type 610 Mica Condenser, as illustrated here, is suitable for use as a Grid Condenser, By-pass Condenser, and in all other cases where a relatively small capacity condenser is employed in a Radio Receiving Circuit. Condensers of inferior design or materials can give rise to losses in a Radio set which are as serious as their source is unsuspected.

For this reason Dubilier Condensers, in common with all other Dubilier Products, are so designed and manufactured as to reduce to the lowest limits all High Frequency and other losses. In the type 610 Condenser the dielectric is of the best Indian Ruby Mica obtainable. Elaborate precautions are taken to keep the assembly of mica and metal sheets closely pressed together so that there is, sensibly, no movement and consequent capacity variation between these sheets when the condenser is in action.



TYPE 610 MICA CONDENSER, showing detachable Dumetohm Clips, fitted in parallel

Your Dealer stocks **DUBILIER** products—ask him

The Dubilier Mica Condenser, Type 610—contd.

The entire element is hermetically sealed into the bakelite moulding of the case, and the condenser is thus impervious to climatic variations. Terminals of the screw type are provided, but connections may be soldered if desired.

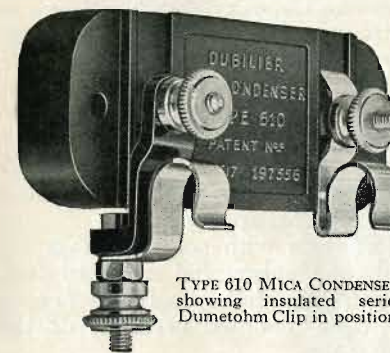

TYPE 610 MICA CONDENSER, showing insulated series Dumetohm Clip in position.

The Type 610 Condenser (page 6) is shown fitted with detachable clips to take the Dumetohm Resistance (see page 15). As the clips are shown on page 6 the Dumetohm will, electrically speaking, be in parallel with the condenser.

Where it is desired to fit the Dumetohm in series with the condenser, the series clip, as shown here, should be fitted in place of one of the metal clips.

Type 610 Condensers are made in 21 different standard capacities between

$0.00005\mu\text{F}$ and $0.015\mu\text{F}$. Capacities between $0.00005\mu\text{F}$ and $0.0005\mu\text{F}$ are supplied complete with detachable Dumetohm clips and with the series clip shown here. For other capacities these clips may be obtained separately (see page 30).

The Dubilier Mica Condenser, Type 620

TYPE 620 Condensers are of vertical design and are intended for use where economy of panel space is necessary.

As will be seen, these condensers are now provided with screw terminals, and are so arranged that they will take either the Parallel or the Series Dumetohm Clips shown with Type 610.

The condenser unit itself is identical with that used in the Type 610 Condenser and the remarks above referring to the range of capacities made and to the supplying of Dumetohm clips apply equally to the Type 620.

In both cases also special prices will be quoted where the limits of accuracy desired are closer than 15% of the rated capacity.

Dimensions :—Distance between fixing hole centres for both Type 610 and Type 620, 2 in.

PRICES—see page 30.



TYPE 620 MICA CONDENSER, showing detachable Dumetohm Clips fitted in parallel.

Your Dealer stocks **DUBILIER** products—ask him

The Dubilier Mica Condenser, Type B775



TYPE B775 MICA CONDENSERS
for Resistance Capacity
Amplifiers.

TYPE B775 are large capacity condensers with Mica Dielectric designed expressly for use as coupling condensers in Resistance Capacity Amplifiers and in other circuits where condensers of large capacity are required to withstand potentials of several hundred volts. They are tested during manufacture at a potential of 500 volts D.C.

They are enclosed in polished black moulded bakelite cases which give a most attractive external appearance.

Screw terminals with soldering tags are provided, and substantial moulded feet, drilled with fixing holes, enable these condensers to be mounted vertically on the panel.

Type B775 Condensers are made in 14 different standard capacities between $0.02\mu\text{F}$ and $0.3\mu\text{F}$.

Dimensions :—Distance between fixing hole centres, $2\frac{3}{8}$ in.

PRICES—see page 30.

The Dubilier "Dubilicon"

THIS Condenser provides eight small condenser units in one case. The two terminals of each condenser unit are soldered to a pair of "Clix" sockets mounted on the lid, and the capacity of each unit is engraved between the pair of sockets forming its terminals.

The whole condenser is enclosed in a polished mahogany box with ebonite lid. The extremely large number of capacities obtainable by series and parallel combinations of the units is apparent, and for experimenters or manufacturers the usefulness of such a standard needs no emphasising.

Full instructions for use are enclosed with every "Dubilicon."

PRICE—see page 30.



A MULTIPLE CONDENSER OF
MAXIMUM CAPACITY
 $0.011\mu\text{F}$.

Your Dealer stocks **DUBILIER** products—ask him

DUBILIER MANSBRIDGE CONDENSERS



DUBILIER MANSBRIDGE
CONDENSER, TYPE BB.

IN MAROON MOULDED
BAKELITE CASES

THE term "Mansbridge Condenser" has, through usage, become loosely employed to include all condensers of a certain type whether of British or of Foreign manufacture. In order that no misapprehension may exist we feel it necessary to point out that there is in this or in any other country only one wireless condenser for the manufacture of which the inventor, Mr. G. F. Mansbridge, is now responsible.

It is the Dubilier Mansbridge Condenser, and we can accept no responsibility for any other condenser of the "Mansbridge Type."

Dubilier Mansbridge Condensers are made in a variety of patterns for various uses. These are set forth in the following pages. Each pattern is designated by its own pattern letter, and additional letters are employed to indicate the working conditions for which the condenser in question has been designed.

The tables following, besides giving for the benefit of constructors full data concerning the physical dimensions of the condenser cases, show the maximum recommended working voltages in each category. These working voltages allow an adequate factor of safety for the condenser. If a long working life is desired, the condenser should not be operated at a voltage in excess of that stated below, while, even for test purposes, the voltage should on no account exceed double the working voltage, since the prolonged application of excessive voltage always tends to produce rapid deterioration of any dielectric.

Dubilier Mansbridge Condensers, Type BB

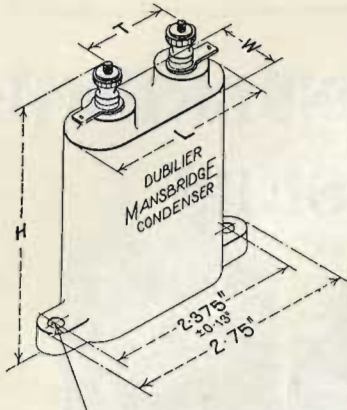

2 HOLES EACH 0.156" DIA. ±0.005"

FIGURE 1.

THESE condensers have been specially designed for use in conjunction with Broadcast radio receivers and similar apparatus. They are supplied sealed into substantial moulded bakelite boxes. The condensers are thereby thoroughly insulated and sealed against the harmful action of moist air, etc. This pattern is only supplied for a maximum working voltage of 150 volts D.C. (300 volts D.C. test). The table below gives dimensions for the two sizes of bakelite box. A full list of capacities and prices for this and all other Mansbridge condensers will be found on page 30.

TYPE BB CONDENSERS (FIGURE 1)
Maximum Working Voltage 150 volts D.C.

Capacity	T	L	W	H
0.5 & 1 μF ..	1"	2"	1 1/2"	3"
2	1"	2"	1"	3"

Dubilier Mansbridge Condensers, Type B

TYPE BA CONDENSERS IN METAL BOXES
Maximum Working Voltage 150 volts D.C. (FIG. 2)

Capacity.	T	L	C	D	W	P	H	O
Up to 0.5 μF ..	—	1 1/2"	2 3/8"	2 1/4"	2"	—	2 1/4"	2 3/4"
1	3/4"	1 1/2"	"	"	1 1/4"	—	"	"
2	"	1 3/4"	"	"	"	—	"	"
3	"	1 3/4"	"	"	"	—	"	"
4	"	2 3/8"	"	"	"	—	"	"
5	"	3 1/4"	"	"	1"	—	"	3 1/2"
6	"	"	"	"	"	—	"	"
8	"	3 1/4"	"	"	2 1/2"	—	"	3 1/4"
10	"	"	"	"	"	—	"	"

TYPE BC CONDENSERS IN METAL BOXES
(FIGURE 3, page 11)
Maximum Working Voltage 200 volts D.C.

Capacity.	T	L	C	D	W	P	H	O
1 μF ..	3/4"	1 1/2"	2 3/8"	2 1/4"	2 1/8"	—	2 1/4"	2 3/4"
2	"	1 3/4"	"	"	1 1/4"	—	"	"
3	"	1 3/4"	"	"	"	1"	"	"
4	"	2 3/8"	"	"	"	—	"	3"
5	"	3 1/4"	"	"	"	2"	"	3 1/4"
6	"	"	"	"	"	—	"	"
8	"	5 1/4"	"	"	"	3"	"	"
10	"	"	"	"	"	—	"	"

* This condenser can be supplied in a box with the following dimensions if specially ordered:—

—	3/4"	3/4"	2 3/8"	2 1/4"	1 1/4"	—	2 1/4"	2 3/4"
---	------	------	--------	--------	--------	---	--------	--------

TYPE BD CONDENSERS IN METAL BOXES
(FIGURES 2 and 3)
Maximum Working Voltage 300 volts D.C.

Capacity.	T	L	C	D	W	P	H	O
1 μF ..	3/4"	1 1/2"	2 3/8"	2 1/4"	2 1/8"	—	2 1/4"	2 3/4"
2	"	1 3/4"	"	"	1 1/4"	1"	2 1/4"	3"
3	"	2 3/8"	2 3/8"	3"	2 1/4"	"	"	3 1/2"
4	"	"	"	"	"	2 1/2"	"	3 1/4"
5	"	3 1/4"	"	"	"	"	"	"
6	"	"	"	"	"	3 1/2"	"	"
8	"	5 1/4"	"	"	"	"	"	"
10	"	"	"	"	"	—	"	"

* This condenser can be supplied in a box with the following dimensions if specially ordered:—

—	3/4"	1"	2 3/8"	2 1/4"	1 1/4"	—	2 1/4"	2 3/4"
---	------	----	--------	--------	--------	---	--------	--------

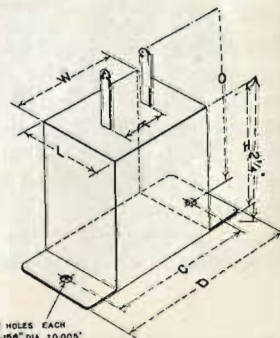

FIGURE 2.

Dubilier Mansbridge Condensers, Type LA

THESE condensers are suitable for higher operating voltages than the Type B condensers, and are more particularly recommended for use in conjunction with Battery Eliminators and other smoothing or filter circuits.

They are higher grade condensers than the Type B and have lower internal electrical losses. They are also suitable for use on A.C. circuits when required. These condensers are provided with tag terminals for soldered connections (Figure 4), but condensers supplied with screw terminals can be obtained, if specially ordered, at a slightly increased cost. These condensers are supplied in various grades suitable for different working voltages as set out in the following tables:—

TYPE LAA CONDENSERS (FIGURE 4)

Maximum Working Voltage 350 volts D.C.

Maximum Working Voltage 240 volts A.C.

Capacity.	T	L	C	D	W	P	H	O
1 μF ..	3/4"	1 1/2"	2 3/8"	2 1/4"	1 1/4"	—	4 1/4"	5 1/4"
2	"	1 3/4"	"	"	"	—	"	"
3	"	1 3/4"	"	"	"	—	"	"
4	"	1 3/4"	"	"	"	—	"	5 1/2"
5	"	2"	"	"	"	1"	"	"
6	"	2 1/4"	"	"	"	"	"	"
8	"	2 3/4"	"	"	"	"	"	"
10	"	3 1/4"	"	"	"	"	"	"

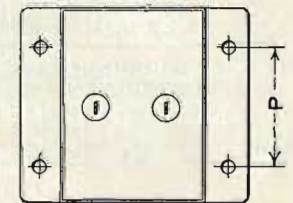
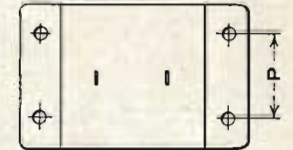
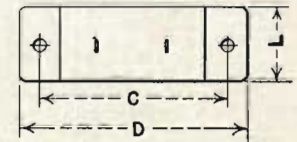
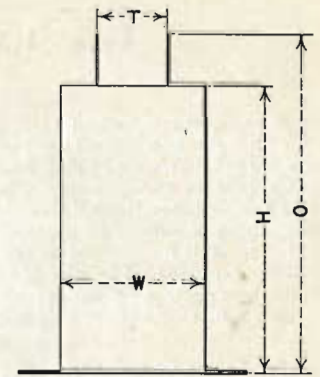

FIGURE 4.

TYPE LAC CONDENSERS (FIGURE 4)

Maximum Working Voltage 600 volts D.C.

Maximum Working Voltage 400 volts A.C.

Capacity.	T	L	C	D	W	P	H	O
1 μF ..	1"	1 1/2"	2 3/8"	2 1/4"	2 1/8"	—	4 1/4"	5 1/4"
2	"	1 3/4"	"	"	"	—	"	"
3	"	1 3/4"	"	"	"	1"	"	"
4	"	2 1/4"	"	"	"	"	"	5 1/2"
5	"	2 3/8"	"	"	"	"	"	"
6	"	3 1/4"	"	"	"	"	"	"
8	"	4 1/4"	"	"	"	"	"	5 3/4"
10	"	5 1/4"	"	"	"	"	"	"

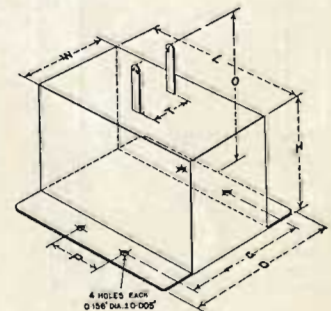

FIGURE 3.

Dubilier Mansbridge Condensers for

H.T. Supply Units or "Battery Eliminators."

Types LAD, LAE, LAF and BE.

IN the construction of H.T. Supply Units (or "battery eliminators") it is essential that the condensers used should have an adequate factor of safety. For this reason the Types LAA and LAC condensers listed above are particularly recommended, in preference to those having a lower test voltage and therefore lower factor of safety. For convenience in the assembly of eliminators single condenser units or "blocks" containing a variety of capacity values are useful, these various sections or tappings being suitable for connection to the input and to the output of the filter and to the various voltage tappings. The special units listed below, Types LAD and LAE, also provide a condenser section for connection in the earth lead of the eliminator. For use with A.C. supply units or battery eliminators, particularly those employing a Raytheon type of

rectifier, a special "Bridging" condenser is provided for connection across the secondary of the supply transformer (Figure 7). The centre terminal of this condenser should be connected to earth.

TYPE LAD CONDENSERS (FIGURES 5 & 6)
Maximum Working Voltage 200 D.C.

Total Cap.	Cap. Tapp'gs.	Fig.	L	C	D	W	P	H	O
12.7 μ F ..	6, 4, 1, 1, 0.5, 0.1, 0.1 ..	5	2 $\frac{3}{4}$ "	3"	3 $\frac{3}{8}$ "	3 $\frac{3}{8}$ "	2"	5 $\frac{1}{2}$ "	6"
13.5 ,, ..	2, 2, 8, 1, 0.5	6	4 $\frac{1}{4}$ "	5 $\frac{1}{8}$ "	5 $\frac{1}{2}$ "	2 $\frac{1}{4}$ "	1"	5 $\frac{1}{2}$ "	6"

TYPE LAE CONDENSERS (FIGURES 5 & 6)
Maximum Working Voltage 450 D.C.

Total Cap.	Cap. Tapp'gs.	Fig.	L	C	D	W	P	H	O
12.7 μ F ..	6, 4, 1, 1, 0.5, 0.1, 0.1 ..	5	4 $\frac{1}{8}$ "	4 $\frac{1}{8}$ "	4 $\frac{7}{8}$ "	4 $\frac{1}{8}$ "	2 $\frac{1}{2}$ "	5 $\frac{1}{2}$ "	6"
13.5 ,, ..	2, 2, 8, 1, 0.5	6	4 $\frac{1}{8}$ "	4 $\frac{1}{8}$ "	4 $\frac{7}{8}$ "	4 $\frac{1}{8}$ "	2 $\frac{1}{2}$ "	5 $\frac{1}{2}$ "	6"

TYPE BE CONDENSERS (FIGURES 5 & 6)
Maximum Working Voltage 120 D.C.

Total Cap.	Cap. Tapp'gs.	Fig.	L	C	D	W	P	H	O
12.7 μ F ..	6, 4, 1, 1, 0.5, 0.1, 0.1 ..	5	3"	3 $\frac{3}{8}$ "	3 $\frac{3}{8}$ "	3 $\frac{1}{4}$ "	2"	2 $\frac{1}{2}$ "	3"
13.5 ,, ..	2, 2, 8, 1, 0.5	6	4 $\frac{1}{4}$ "	5 $\frac{1}{8}$ "	5 $\frac{1}{2}$ "	1 $\frac{1}{4}$ "	1"	2 $\frac{1}{2}$ "	3"

TYPE LAF "BRIDGING" CONDENSER (FIGURE 7)
Maximum Working Voltage 350 A.C.

Total Cap.	Cap. Tapp'gs.	Fig.	L	C	D	W	P	H	O
0.2 μ F ..	0.1+0.1. For Dimensions, see Figure 7.								

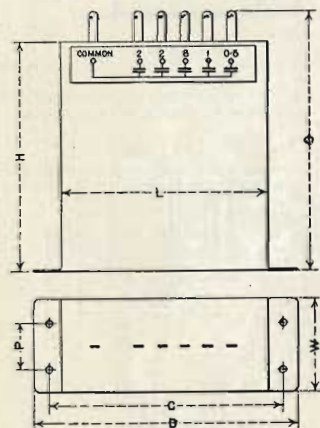

FIGURE 6.

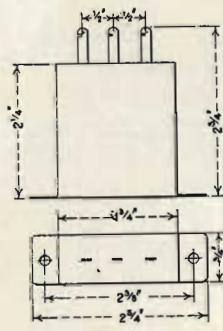

FIGURE 7.

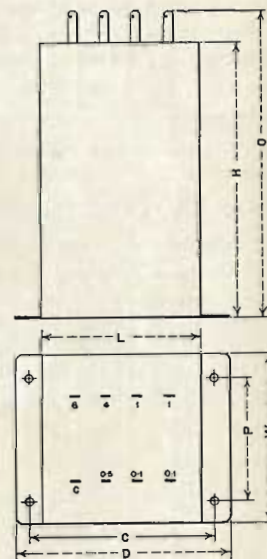

FIGURE 5.

SECTION TWO

Resistances

- The Duwirohm Anode Resistance
- The Non-Metallic Anode Resistance
- The Dumetohm
- The Duvarileak
- The Duvolcon
- The Resistor
- The Resistance Capacity Unit

The Dubilier "Duwirohm" Resistance



THE "DUWIROHM" ANODE RESISTANCE.

THE "Duwirohm" as its name implies is a wire-wound Resistance. Constructed with a special type of non-inductive winding which permits a potential of several hundred volts to be carried in safety, it is

admirably suited for use in resistance capacity coupled amplifiers.

The particular type of construction employed enables these Resistances to be graded to a close degree of accuracy and also makes it possible to ensure absolute constancy under all conditions.

Constructors will find "Duwirohms," with their accurate and constant values, indispensable for research work and experiments.

Duwirohms are made in standard resistance values of 10,000, 20,000, 30,000, 40,000, 50,000, 60,000, 70,000, 80,000, 90,000, 100,000, 150,000, 200,000, 250,000 and 300,000 ohms, other resistance values being obtainable to order. Holders with screw terminals, as shown, are obtainable at small extra cost.

Dimensions:—Distance between fixing hole centres, $3\frac{1}{8}$ in.

PRICES—see page 31.

The Dubilier Non-Metallic Resistance

DUBILIER Non-metallic Anode Resistances, tested to a D.C. voltage of 200 volts, have extremely low self-capacity and are absolutely non-inductive. They are therefore particularly recommended for use in High Frequency Anode circuits, and are in every way thoroughly reliable.

They are made in resistance values of 20,000, 30,000, 40,000, 50,000, 60,000, 70,000, 80,000, 90,000 and 100,000 ohms. Holders, as illustrated, are obtainable at small extra cost.

Dimensions:—Distance between fixing hole centres, $3\frac{1}{8}$ in.

PRICES—see page 31.



THE NON-METALLIC ANODE RESISTANCE.

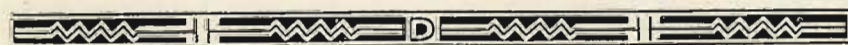

The Dubilier "Dumetohm"



THE correct pronunciation of the word "Dumetohm" is Dew—met—ohm. It is a Dubilier Resistance "of a metallic nature."

Since we introduced this Resistance a little over a year ago, its popularity has gone up by leaps and bounds.

The public have discovered that both as a Grid Leak and also, in certain values, as an Anode Resistance, the Dumetohm possesses several qualities which place it in a class by itself and make it far and away superior to any other resistance on the market.

Carbon, as is well known, falls off rapidly in resistance value with an increase of temperature, whether this temperature be due to climatic conditions or to the heat produced by passage of current. Resistances therefore which depend upon some form of carbon are for the most part liable to this disadvantage.

There is, in addition, a distinctly erratic behaviour on the part of some resistances under the application of voltage. Thus a Grid Leak showing $3\text{ M } \Omega$, when measured with an applied E M F of 2 or 3 volts, may fall when 100 volts is applied to a resistance which renders it useless for the functions it is expected to perform. The Dumetohm is free from such troubles and is noiseless and constant in action.

No climatic temperatures likely to be experienced on this earth will cause a serious drop in its resistance, neither will anything short of an intentional gross overload. When we add to these ideal qualities the fact that neither self-inductance nor self-capacity can be present in the single straight golden-coloured rod which forms the resistance element of the Dumetohm, it is not difficult to understand why it has become "easily the most popular resistance in the country."

The Dumetohm, which is intended to be used in conjunction with our Types 610 and 620 Condensers and with the resistance capacity coupling unit (see page 18), is made in resistance values of 0.25, 0.5, 1, 1.5, 2, 3, 4, 5 and 10 megohms.

The Dumetohm Holder

THE soldering of connections to the Dumetohm is a delicate operation and we recommend the use of one or other of the following three types of clip:—

- A pair of clips for use with our Type 610 or Type 620 condensers.
- A special insulated clip for using the Dumetohm in series with the 610 or 620 condensers.
- The Dumetohm Holder (see illustration) for use where it is required to mount the Dumetohm separately.

Dimensions:—Distance between fixing hole centres of holder, 2 in.

PRICES—see page 31.

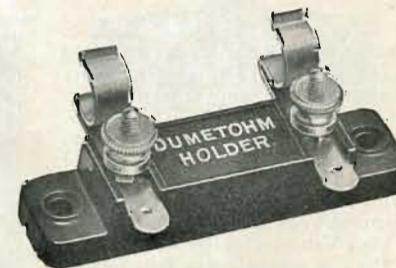

Your Dealer stocks **DUBILIER** products—ask him

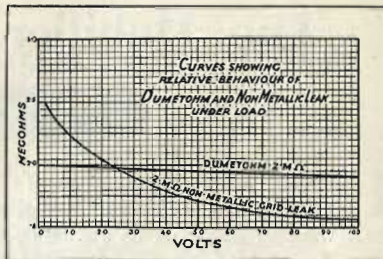
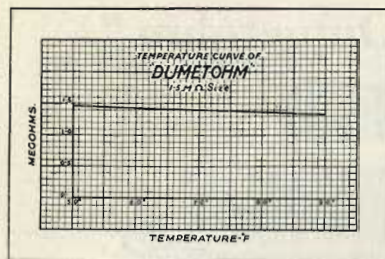

Curves showing the consistent behaviour of the Dumetohm under (left) a rise in temperature from 50° to 90° F. and (right) an applied E.M.F. from 0 to 100 volts. The behaviour of a non-metallic leak is shown in contrast.

The Dubilier Filament Resistor

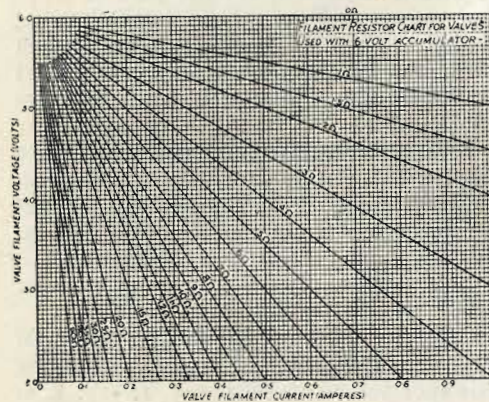

CONSTRUCTORS frequently desire to compare results in the same circuit from valves of various filament voltages. If, say, a 2-volt valve is to be included in a circuit supplied by a 6-volt accumulator, a Resistor is required to obtain the necessary fall of potential. A comprehensive range of Dubilier Filament Resistors has therefore been introduced as follows:—

STANDARD VALUES

Resistance	Max. Cur. Carr. Cap.	Resistance	Max. Cur. Carr. Cap.
Short Circuit	2.0 Amps	11 ohms	0.25 Amps
1.0 ohm	1.0 "	12 "	0.25 "
1.5 "	0.8 "	15 "	0.25 "
2 "	0.7 "	20 "	0.1 "
3 "	0.6 "	25 "	0.1 "
4 "	0.5 "	30 "	0.1 "
5 "	0.4 "	40 "	0.1 "
6 "	0.4 "	50 "	
7 "	0.25 "		
8 "	0.25 "		
9 "	0.25 "		
10 "	0.25 "		

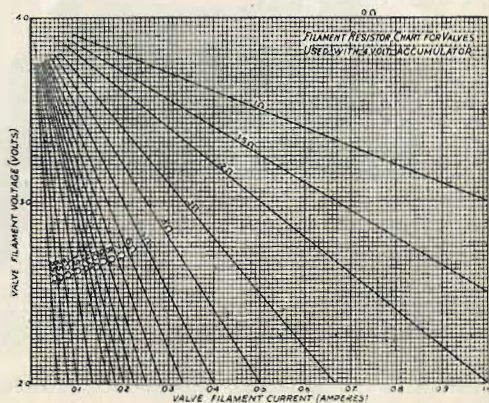

The Dubilier Resistors are designed to fit the Dubilier Dumetohm Holder (see page 15), thus making them readily interchangeable. The accompanying Charts make it simple to determine the value of Resistor required in any given case. Plot the point of intersection between normal Filament Volts and Filament Amps. of your Valve. The Resistor to order is the one whose curve falls immediately on or below this point. These Resistors are inexpensive, and no constructor should be without a range of the more common values.

PRICES—see page 31.

Your Dealer stocks **DUBILIER** products—ask him

The Dubilier "Duvarileak"



THE "DUVARILEAK"
VARIABLE GRID LEAK
(Patent Nos. 236975 & 246325)

THE importance of employing a variable Grid Leak in receivers has long been recognised. The difficulty hitherto has always been to devise a resistance which, within small physical dimensions, shall be variable between 0.25 and 5 megohms, and which shall retain indefinitely its constancy of variation over the entire range.

After more than three years of research work we have succeeded in producing a resistance material having an extremely hard surface, and otherwise complying with the requirements of the case.

The rotating arm makes a rolling contact with the resistance material, thus ensuring that wear shall be negligible.

Consequently the "Duvarileak" has a permanence of adjustment unequalled in any other type of variable grid leak, and it can be set to any given resistance value time after time by means of the graduated scale provided.

Dimensions:—One-hole fixing, $\frac{1}{8}$ in. clearance; Diameter of case, $2\frac{3}{8}$ in.; Projection behind panel, $1\frac{1}{4}$ in.

PRICES—see page 31.

The Dubilier "Duvolcon"

THE Duvolcon is intended to be used as a convenient means of controlling the volume of sound from a Radio receiver without altering the tuning of the set.

The nature of the Resistance Element as well as the appearance of this instrument is similar to that of the Duvarileak, except that three terminals are provided and the resistance is of a lower value.

A further use for the Duvolcon is to control the reaction of a Receiver, with, again, the great advantage that the tuning of the Grid Circuit of the set is not altered.

A leaflet giving circuit diagrams illustrating circuits containing a Duvolcon and the method of connecting is enclosed with each instrument and will gladly be forwarded separately on request.

Dimensions are the same as for the Duvarileak.

PRICES—See page 31.



THE "DUVOLCON"
VOLUME CONTROL
(Patent Nos. 236975 & 246325)

Your Dealer stocks **DUBILIER** products—ask him

The Dubilier R.C. Coupling Unit

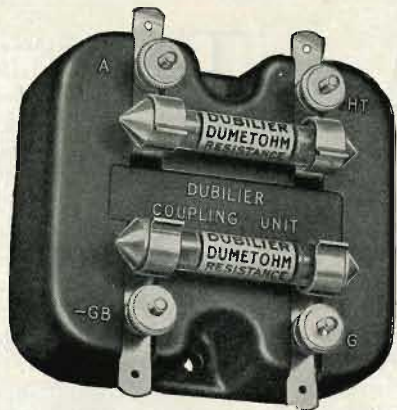

RESISTANCE Capacity Coupling is a method of amplification of Radio Signals which can give particularly clear and pure results. Neither is there any reason why volume should be sacrificed by this method. If disappointing results have been experienced with R.C. Coupling it is almost certain that the cause has been a failure to select carefully the various components of the circuit.

The Dubilier R.C. Coupling Unit has been designed for use with high-amplification-factor valves, such as the Osram DEH 610, 410, and 210, the B.T.H. Co.'s B8 and other similar valves. With these the Dubilier Unit will be found to give almost perfectly uniform amplification over the entire range of audible sounds.

The famous Dumetohms are employed in this Unit, and the surprising success which has attended its introduction is due in no small measure to the consistent behaviour of the Dumetohms and to the fact that the complete absence of self-inductance and self-capacity makes these Resistances ideal for this purpose.

The Dumetohm values which we recommend for use with the Coupling Unit are: Anode, 1 megohm; Grid, 3 megohms. Since, however, the Dumetohms are readily detachable, other values may be employed if you so desire.

Both screw terminals and soldering tags are provided and the method of connecting up this unit in a circuit is given in the accompanying diagram. The Terminal marked “—GB” on the unit is intended for connection to the negative terminal of the Grid Bias Battery. Alternatively this terminal should be joined to the negative $L T$ terminal of the receiver.

Dimensions:—Distance between fixing hole centres, 2in.

PRICE—see page 31.

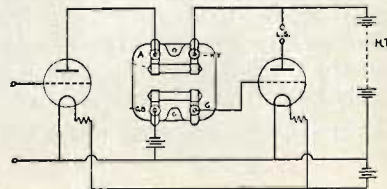

SECTION THREE

The Dubilier Toroids

The Dubilier K.C. Variable Condenser

The Dubilier “Univane” Variable Condenser



Your Dealer stocks **DUBILIER** products—ask him

The Dubilier Toroids

(Patent No. 272448)



THE BROADCAST
TOROID
500 to 1,300 K.C.
(600 to 230 metres)

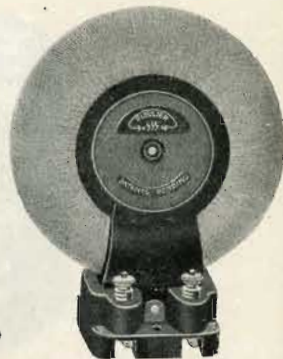

THE LONG WAVE
TOROID
150 to 400 K.C.
(2,000 to 750 metres)

H.F. TRANSFORMERS have, in the past, suffered from the disadvantage that if placed in close proximity in a radio receiver they set up oscillations owing to interaction of electro-magnetic fields. This effect can be minimised by providing metallic shields, but if this is done, further H.F. losses are experienced owing to the presence of the metal.

The Dubilier Toroid has, therefore, been designed to eliminate these disadvantages entirely. Owing to our special process of winding the coils, which, as will be seen, provides that there is no gap between the turns at the outer circumference of the coil, the electro-magnetic field is restricted to the physical limits of the coil itself. This unique property not only enables Toroids to be fitted close together without fear of interaction, but it makes them completely free from losses which might be caused by adjacent metal work.

In addition there is the great advantage that the Toroid is in no way affected by the presence of even powerful electro-magnetic fields, and stable working, even in the immediate vicinity of large Broadcasting Stations, is assured.

Dubilier Toroids are made in two ranges as above, and, as they plug into the 4-point holders shown, rapid interchange is assured. Each Toroid is supplied with a detachable holder.

Whether used as an H.F. Transformer or in conjunction with a variable air condenser as a coupler, the Dubilier Toroid will be found to give highly efficient results.

Where two or more stages of H.F. amplification are employed, a tapping for neutralisation purposes is commonly used, and we, therefore, produce tapped models in both the wavelength models mentioned.

A full explanation of these wonderful components together with diagrams and circuits is given in our booklet, "The Story of the K.C. and the Toroid," a copy of which will be forwarded on request, price 3d.

Dimensions:—Distance between fixing hole centres of holder, 1 1/8 in.

Overall height of Toroid in holder, 5 in.

PRICES—see page 31.

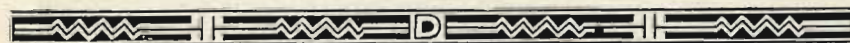

Your Dealer stocks **DUBILIER** products—ask him

The Dubilier "K.C." Condenser

(Patent Nos. 237286, 243873, 263519)

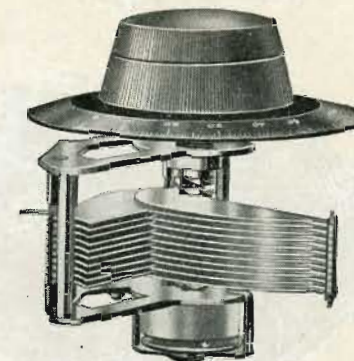

THE modern system of spacing Radio Transmitting Stations according to their oscillation frequencies necessitates the use in Receiving Sets of variable condensers also designed according to the kilocycle law.

Numerous condensers claiming to follow this law have been produced lately, but it will be obvious, upon reflection, that such a claim can only be justified provided that the constants of the circuit to be associated with the condenser are stated. No condenser can give S. L. F. tuning irrespective of the circuit in which it is used.

The Dubilier K.C. Condenser has been designed to give true kilocycle (or S. L. F.) tuning when used in conjunction with either of the Dubilier Toroids. It will also give these results in conjunction with other coils provided that the effective capacity shunted across the condenser is of the correct value. As an instrument the Dubilier K.C. Condenser is highly efficient and most attractive in appearance. The rotary vanes are connected to the end plates which are normally connected to earth or to a low potential point in the circuit. The fixed vanes are held insulated by bakelite pillars in compression, thus giving very low dielectric losses. The vanes themselves are of brass, which tends still further towards the reduction of losses.

A special slow motion drive is employed giving a reduction ratio of 200 to 1, and one hole fixing is arranged.

The maximum capacity is 0.0005 μ F.

A full description of this Condenser and of the Dubilier Toroids will be found in our booklet, "The Story of the K.C. and the Toroid," price 3d.

Dimensions:—Fixing hole, 1/2 in. clearance; Diameter of dial, 4 in.; Sweep of rotary plates, 2 3/8 in. from centre.

Projection behind panel, 2 1/4 in.

PRICE—see page 31.

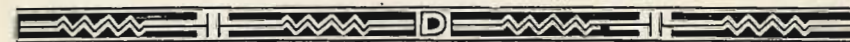

Your Dealer stocks **DUBILIER** products—ask him

The Dubilier "Univane" Condenser

(Patent No. 247365)

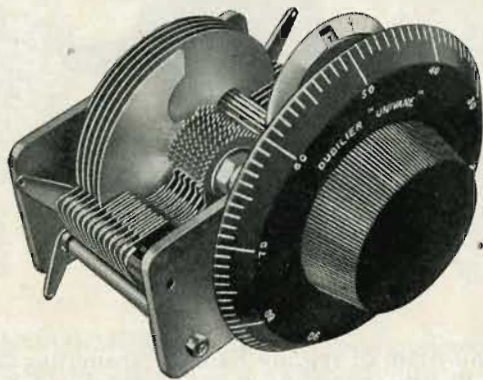

THIS type of variable condenser provides the electrical equivalent of a mechanical vernier gearing throughout the full range of the condenser, but it does this without the disadvantages attendant upon the ordinary variable condenser with a single movable vane to give vernier tuning.

The condenser is so designed that this desirable feature is accomplished by a simple arrangement, the rotation of the knob of the condenser moving *only one vane of the condenser at a time*. As soon as one movable vane has been rotated into position where it interleaves with the fixed vanes, a second vane is picked up and is rotated into position as the knob is turned. Thus the full movement from minimum capacity to maximum capacity requires several complete revolutions of the condenser tuning knob, thus enabling exceptionally fine tuning to be obtained. The number of times that the knob has been rotated is shown on a small auxiliary indicator attached to the front of the instrument and in close proximity to the dial. By means of this indicator a permanent log of every station heard may be kept for future reference.

The "Univane" is suitable for use in all types of radio receiving sets, and is highly recommended where fine and accurate tuning is required.

Maximum capacity 0.0005 μ F.

Dimensions:—Diameter of dial, 4in. Extreme width of condenser, 4½in.
Projection behind panel, 1½in.

PRICE—see page 31.

SECTION FOUR

The Dubilier H.T. Supply Units
The "Dubrescon"
The "Ducon"
The "Minicap" Switch
The Mansbridge Variometer
Dubilier Condensers for special purposes



The Dubilier H.T. Supply Units



MODEL No. 2 D.C. (DE LUXE)

DUBILIER H.T. Supply Units are manufactured in three models so that they are made to cover the full range of radio receivers at present on the market and also the various different supply voltages and frequencies at present in use in this country.

The Units are designed to comply with the wiring rules of the Institution of Electrical Engineers, and, in installing them, the above regulations should be complied with.

There is only one alteration necessary in connecting the H.T. Unit to a set which has been previously supplied by batteries. The earth connection to the radio set *must* be removed and connected to the earth terminal provided on the Unit. The usual aerial connection is left untouched, but no wire should be connected to the earth terminal of the radio set. In cases where a frame aerial is used and no earth is usually employed, an earth wire should be connected to the earth terminal of the H.T. Unit.

These Units are designed so that the same smoothing system is used on the A.C. and D.C. models, and in order to convert a D.C. model to an A.C. model it is merely necessary to add the A.C. Rectifier Unit.

As will be seen, the three units are mounted in moulded containers with special lifting ledges, and flexible leads with suitable plugs for connection to the electric supply are supplied as well as (in the D.C. models) multi-colored cables suitably labelled and coloured for the various H.T. tappings.



The Dubilier H.T. Supply Units



MODEL No. 1. D.C.

THE D.C. Unit is made in two ranges:—

Model No. 1.—This is designed for use on small sets where a large number of valves is not in use. Three different H.T. Supplies are available, two being fixed at values pre-determined by the voltage of the supply mains, and one being variable and controlled by the knob and dial on the lid of the Unit.

Model No. 2.—This is designed for use on large multi-valve sets where extra special filtering is required. It is termed the De Luxe Model (see illustration opposite). Four different H.T.

voltages are available, two being fixed and two variable.

Model No. 3.—For A.C. Circuits it is necessary to employ this Rectifier Unit. It is connected to the supply mains by the plug provided; Model No. 1 or No. 2 is then connected by plugging in to the bayonet socket on the lid. The special Dubilier Rectifying Valve S.D. 800 is supplied with this Unit.

Full instructions are supplied with each Unit, but in ordering it is essential to state clearly the supply voltage and (if A.C.) the frequency.

Dimensions:—Height of all three models,
8in.

PRICES—see page 31.



MODEL No. 3. A.C. RECTIFIER.



The Dobilier "Dubrescon"



IN experimental work, where a circuit may be taken down and re-connected many times at a sitting, it is, unfortunately, all too easy to let a live H.T. lead fall upon or otherwise come into contact with part of the filament circuit, with disastrous results to one's pet valve.

And even when the set is a completely-assembled one, a momentary distraction may cause one to attempt to put in a valve wrong way round, with equally fatal results to the filament. Fuses do not always blow when they should, and when they do they need renewing.

The "Dubrescon" overcomes all these difficulties. It is not a fuse.

It is a permanent safety device which, fitted in one of the H.T. Battery Leads, positively prevents any sudden rush of H.T. current, while at the same time allowing complete freedom to the passage of H.F. current.

To the experimenter the "Dubrescon" is a necessity.

To the ordinary listener it is little less.

Note.—When more than four valves are in use you are advised to use two "Dubrescons."

Dimensions:—Distance between fixing hole centres, 4in.

PRICE—see page 31.

The Dobilier "Ducon"

THE "Ducon," affording a simple, efficient and perfectly safe means of employing the electric lighting mains as an aerial, has proved its value during the past five years in hundreds of thousands of cases.

It is an ideal accessory for use where an outside aerial is either difficult to erect or is considered unsightly; it enables a receiving set to be used in any room of the house containing an electrical point, and in many cases it will effect considerable improvement in reception when used in conjunction with an orthodox "earth."

Reception, whether from Local or Distant stations, is as good as, and in many cases superior to, that obtained with an outside or a frame aerial, but it should be noted that the various methods of connection indicated on the leaflet accompanying each "Ducon" should be carefully tried in order to obtain optimum results from any particular lighting system. The "Ducon" consumes no current whatever from the mains, does not affect the lighting system, and is tested prior to despatch at a pressure of 2,500 volts. It is not recommended for use with crystal sets.

PRICE—see page 31.



The Dobilier "Minicap" Switch

(Patent No. 210337)

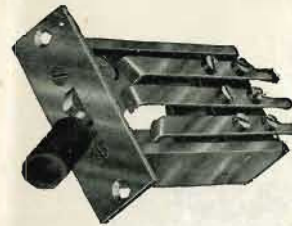

IT is generally recognised that the employment of switches in wireless receiving sets usually involves the introduction of undesirable capacity effects between the switch contacts.

It is to avoid these stray capacities that the Dobilier "Minicap" Switch has been designed. From the illustration it will be seen that the switch is arranged with the

terminal strips placed edge to edge, thus giving minimum capacity surfaces. The terminals have substantial tags for soldering, and the frame is solidly constructed of a special metallic alloy. The strips are firmly screwed to two ebonite blocks, and the contacts are of the self-cleaning rubbing type. The whole switch is very well finished and suitable for panel mounting.

The "Minicap," which is a double-pole double-throw switch, is useful in all circumstances as a general purpose switch, including use as a Reversing Switch, Series-Parallel Switch for Aerial Circuit, Circuit Change-over for valve receiver, control switch for both H.F. and L.F. Valves, and Wave-length control switch (simultaneous control of tuning range and reaction). Dimensions:—Distance between centres of fixing holes on face plate, 1½in.

PRICE—see page 31.

The Dobilier Mansbridge Variometer

(Patent No. 224976)

THE variometer method of tuning has each year an increasing number of enthusiastic adherents, and amongst these the Dobilier Mansbridge Variometer has become deservedly popular. It is a compact, reliable and highly efficient instrument consisting of four D-shaped coils, two of which are rotated in respect to the other two by means of the knob.

An important feature of this variometer is the connection to the moving coil. This is a phosphor-bronze spiral which, winding and unwinding as the knob is moved, ensures a permanent soldered connection with the moving coils and obviates all the weakness of rubbing contacts.

By means of links the coils can be strapped together in series or in parallel, and in this way all British Broadcasting Stations come within the wavelength range of the instrument.

In addition to ordinary crystal and valve set reception, the Dobilier Mansbridge Variometer is useful for buzzer and heterodyne wave meters, tuned anode receivers, etc., etc.

The variometer is supplied with legs, and also with fixing holes beneath the dial for panel mounting.

A drilling template and a diagram leaflet are supplied with each variometer.

PRICE—see page 31.



Your Dealer stocks **DUBILIER** products—ask him

Dubilier Condensers for Special Purposes

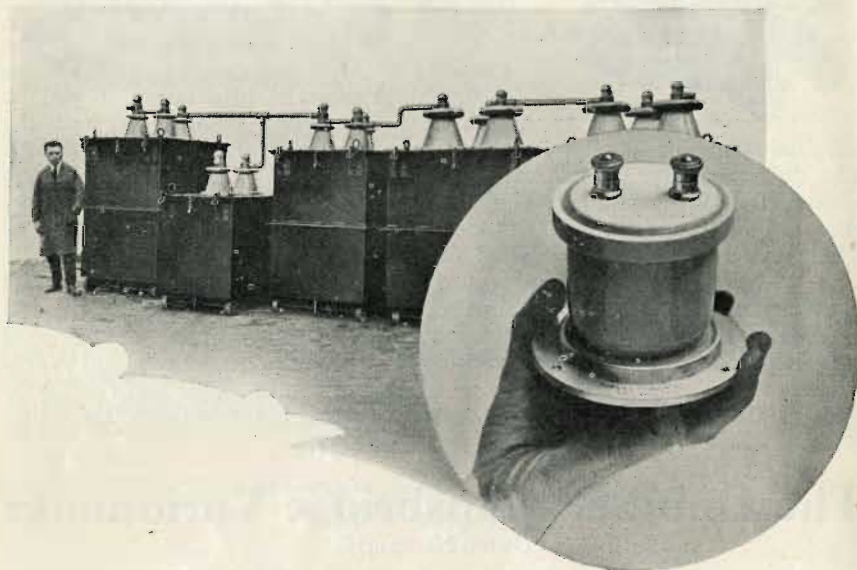

Condensers of all sizes!

IN addition to the Receiving Condensers mentioned in this Catalogue we have a wide range of Condensers for Low, Medium and High Power Transmitting Stations.

Experimenters and Engineers are invited to consult us regarding their requirements and we shall at all times be pleased to quote for the making of Condensers for specialised or experimental purposes.

When submitting enquiries for Condensers for use in transmitting apparatus the following information is required to enable us to quote by return:—

1. Capacity of Condenser in microfarads.
2. Position in circuit where Condenser will be employed.
3. Maximum working voltage (A.C. or D.C.).
4. Current in circuit.
5. Wavelength at which transmitter will be operating.

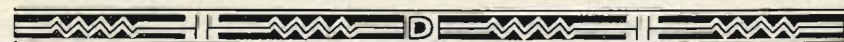

Accredited Agents of Dubilier Condenser Co. (1925) Ltd.

BRITISH ISLES

ABERDEEN Thomson & Brown Bros., Ltd., 74 Huntley Street.	EDINBURGH Thomson & Brown Bros., Ltd., 126 George Street.
BIRMINGHAM S. Wilding Cole, Ltd., 62 Moor Street.	GLASGOW Thomson & Brown Bros., Ltd., 65 Mitchell Street.
BRADFORD F. Riddiough & Son, Westgate.	MANCHESTER Manchester Radio Co., Ltd., 155 Oxford Road.
BRISTOL F. Burris & Sons, 7 to 16 Redcliffe Street.	NEWCASTLE-ON-TYNE Thomson & Brown Bros., Ltd., Carliol Street.
CARDIFF Brown Bros., Ltd., 86-88 Adam Street.	SOUTHAMPTON Brown Bros., Ltd., 33 Carlton Crescent.
DUBLIN Brown Bros. (Ireland), Ltd., Dunlop House, Lower Abbey Street.	
DUNDEE Thomson & Brown Bros., Ltd., 2c King Street.	

ABROAD

AUSTRALIA Amalgamated Wireless Ltd., 47 York Street, Sydney, N.S.W.	HUNGARY United Incandescent Lamps and Elec- trical Co., Ltd., Ujpest 4, near Buda- pest.
AUSTRIA Siemens & Halske, 111-1 Apostelgasse, 12 Vienna.	ITALY S. Belotti & Co., Corso Roma, 76-78 Milan (14).
BELGIUM La Radiophonie Belge, 25 Rue Van Hel- mont, Brussels.	JAPAN Sale & Co., Ltd., 1 Yaesu-Cho, 1 Chome Kojimachi-Chu, Tokyo.
CANADA Canadian General Electric Co., Ltd., Toronto.	Sale & Co., Ltd., 167 Yamashita-Cho, Yokohama.
CZECHO-SLOVAKIA H. Stefflicek, Na Vaclavce 31, Prague.	Sale & Co., Ltd., 46 Harima-Machi, Kobe.
DENMARK Poul Petersen, Store Kirkestraede 1, Copenhagen.	Sale & Co., Ltd., Kajima Bank Build- ings, Osaka.
FRANCE Societe Generale des Condensateurs, et Appareils de Protection Electrique, 27 Rue de Mogador, Paris.	NORWAY Norsk Marconikompani, Raadhusgaten 5b, Oslo.
GERMANY Deutsche Dubilier Kondensator G.m.b.H. Hallesches-Ufer 12-13 Berlin, S.W.1.	SOUTH AFRICA British General Electric Co., Ltd., Magnet House, Corner Loveday and Anderson Streets, Johannesburg.
Gesellschaft fur Drahtlose Telegraphie (Telefunken) Hallesches-Ufer 12-13, Berlin, S.W.11.	SWEDEN U. Salchow, Kl.V.Kyrkogata 12, Stock- holm.
HOLLAND Nederlandsche Seintoestellen Fabriek, Post Box 32, Hilversum.	SWITZERLAND Societe Generale des Condensateurs Electriques, Fribourg.
	U.S.A. Dubilier Condenser Corpn., 4377 Bronx Blvd., New York City, U.S.A.

Dubilier Condenser Co. (1925) Ltd.

PRICE LIST

1927-8

Page 6.—Type 577—
0.0001μF to 0.01μF 7/6

Pages 6 & 7. Type 610 and Type 620—
0.00005μF to 0.0009μF 2/6
0.001μF to 0.006μF 3/-
0.007μF to 0.009μF 3/6
0.01μF 4/-
0.015μF 4/6

Page 6—
Pair of Dumetohm Clips 3d.

Page 7—
Insulated Series Clip 6d.

Page 8. Type B.775—
0.02μF to 0.05μF 5/6
0.06μF 6/6
0.07μF 7/-
0.08μF 7/6
0.09μF 8/-
0.1μF 8/6
0.125μF 10/-
0.15μF 12/-
0.2μF 15/6
0.25μF 19/-
0.3μF 22/6

Page 8—
The "Dubicon" 17/6

Page 10. Dubilier Mansbridge Condensers—
Type BB. 0.5μF 2/10
1.0μF 3/-
2.0μF 4/-

Type BA. 0.01μF to 0.1μF .. 2/-
0.125μF and 0.2μF .. 2/3
0.25μF and 0.3μF .. 2/5
0.4μF 2/7
1.0μF 3/-
2.0μF 4/-
3.0μF 5/-
4.0μF 6/-
5.0μF 8/-
6.0μF 9/-
8.0μF 12/-
10.0μF 15/-

Type BC. 1.0μF 3/3
2.0μF 4/3
3.0μF 5/6
4.0μF 7/-
5.0μF 9/-
6.0μF 9/9
8.0μF 13/-
10.0μF 16/-

Type BD. 1.0μF 3/6
2.0μF 4/9
3.0μF 6/6
4.0μF 8/3
5.0μF 10/-
6.0μF 11/-
8.0μF 14/-
10.0μF 17/-

Page 11. Dubilier Mansbridge Condensers—
Type LAA. 1.0μF 4/9
2.0μF 7/-
3.0μF 10/6
4.0μF 12/6
5.0μF 15/3
6.0μF 18/3
8.0μF 24/9
10.0μF 30/-

Page 11. Dubilier Mansbridge Condensers—contd
Type LAC. 1.0μF 6/3
2.0μF 8/9
3.0μF 13/3
4.0μF 17/6
5.0μF 21/9
6.0μF 26/-
8.0μF 34/-
10.0μF 41/6

Page 12. Dubilier Mansbridge Condensers—
Total Capacity Price
Type LAD. 12.7μF £2 2 6
13.5μF £2 2 6
Type LAE. 12.7μF £2 19 0
13.5μF £2 19 0

Type LAF (Special Bridging Condenser)—
0.1 + 0.1 3/-

Type BE (Battery Eliminator Smoothing Condensers)—
12.7μF £1 2 6
13.5μF £1 2 6

Page 14. The "Duwirohm" Resistance—
10,000 to 100,000 Ω .. 5/- each
150,000 and 200,000 Ω .. 8/- "
250,000 Ω 9/9 "
300,000 Ω 11/6 "

Page 14. "Duwirohm" Holders 1/6 ..

Page 14. The Non-Metallic Anode Resistance—
20,000 to 100,000 Ω .. 4/- "

Page 14. Holders 1/6 ..

Page 15. The "Dumetohm"—
0.25 to 10MΩ each 2/6

Page 15. "Dumetohm" Holders .. 1/-

Page 16. Filament Resistors—
All resistance values 1/-
"Dumetohm" Holders for above .. 1/-

Page 17. The "Duvarileak" .. 7/6

Page 17. The "Duvolcon" .. 7/6

Page 18. The R.C. Coupling Unit, complete with 2 "Dumetohms" 7/-

Page 20. Dubilier Toroids, complete with Holders 10/6

Dubilier Toroids, complete with Holders, Tapped Models .. 11/6

Page 21. Dubilier K.C. Condenser .. 12/-

Page 22. The "Univane" Condenser 25/-

Page 25. Dubilier H.T. Supply Units—
Model 1 D.C. £4 12 6
Model 2 D.C. (De Luxe) .. £8 10 0
Model 3 A.C. (Rectifier) .. £6 6 0

Page 26. The "Dubrescon" .. 6/-

Page 26. The "Ducon" 5/-

Page 27. The "Minicap" 8/-

Page 27. The Mansbridge Variometer 12/6

